

80.6400

ZAWÓR ODCINAJĄCY KULOWY Z GWINTEM WEWNĘTRZNYM
G1/8 DO G3/4
FEMALE BALL VALVE

G	DN	CH	F	M	L	A	H	Nr zamówieniowy Code number
1/8	5,5	14-15	7	7	35	19	21	80.6400.18W
1/4	5,5	14-15	8	8	37	19	21	80.6400.14W
3/8	8	18-19	9	9	42	19	22	80.6400.38W
1/2	10	22-23	10	10	49	26	30,5	80.6400.12W
3/4	14	28-30	12	12	58	26	33	80.6400.34W

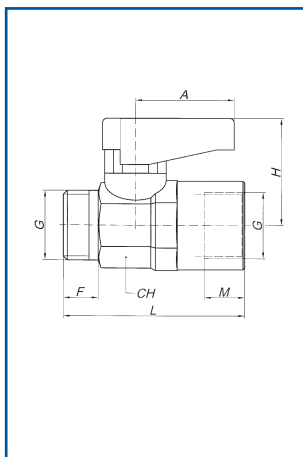

80.6410

ZAWÓR ODCINAJĄCY KULOWY Z GWINTEM WEWNĘTRZNYM
I ZEWNĘTRZNYM G1/8 DO G3/4
MALE - FEMALE BALL VALVE

G	DN	CH	F	M	L	A	H	Nr zamówieniowy Code number
1/8	5,5	14-15	7	7	34	19	21	80.6410.18WZ
1/4	5,5	14-15	8	8	35	19	21	80.6410.14WZ
3/8	8	18-19	9	9	39	19	22	80.6410.38WZ
1/2	10	22-23	10	10	45	26	30,5	80.6410.12WZ
3/4	14	28-30	12	12	52	26	33	80.6410.34WZ

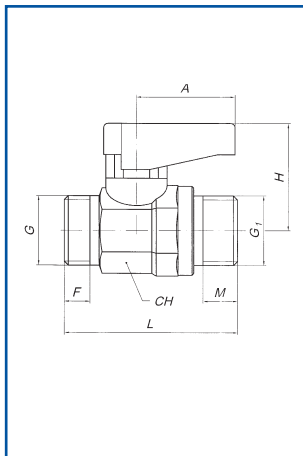

80.6420

ZAWÓR ODCINAJĄCY KULOWY Z GWINTEM ZEWNĘTRZNYM
G1/8 DO G3/4
MALE BALL VALVE

G	G1	DN	CH	F	M	L	A	H	Nr zamówieniowy Code number
1/8	-	1/8 5,5	14-15	7	7	32	19	21	80.6420.1818Z
1/8	-	1/4 5,5	14-15	7	8	32	19	21	80.6420.1814Z
1/4	-	1/4 5,5	14-15	8	8	33	19	21	80.6420.1414Z
3/8	-	1/4 5,5	14-15	9	8	33	19	21	80.6420.3814Z
3/8	-	3/8 8	18-19	9	9	37	19	22	80.6420.3838Z

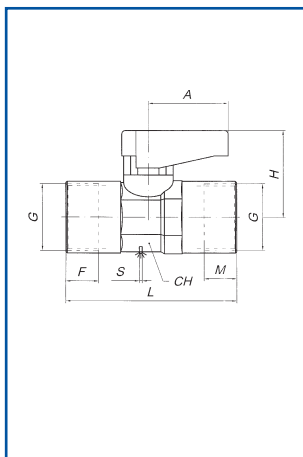

80.6600

ZAWÓR ODCINAJĄCY KULOWY Z GWINTEM G1/8 DO G3/8 Z OD-
POWIETRZENIEM
FEMALE BALL VALVE WITH EXHAUST

G	DN	CH	F	M	L	L1	H	S	Nr zamówieniowy Code number
1/8	5,5	14-15	7,4	7,4	36	19	21	1,5	80.6600.1818
1/4	5,5	14-15	11	11	43	19	21	1,5	80.6600.1414
3/8	8	18-19	11,4	11,4	47	19	22	2	80.6600.3838

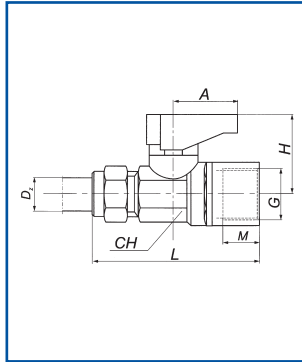

80.6430

ZAWÓR ODCINAJĄCY KULOWY Z PRZYŁĄCZKĄ DO RUREK MIEDZIANYCH Z GWINTEM WEWNĘTRZNYM G1/8 DO G1/2
FEMALE BALL VALVE FOR Cu PA, TUBES

G	D ₁	DN	CH	M	L	A	H	Nr zamówieniowy Code number	
1/8	-	8	5,5	14-15	7	43	19	21	80.6430.1808
1/4	-	8	5,5	14-15	8	43	19	21	80.6430.1408
3/8	-	10	5,5	14-15	9	48	19	22	80.6430.3810
1/2	-	12	8	18-19	9	49	19	22	80.6430.1212
1/2	-	14	10	22-23	10	55,5	26	30,5	80.6430.1214

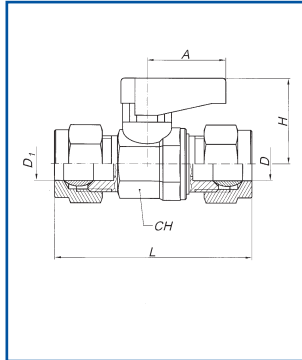
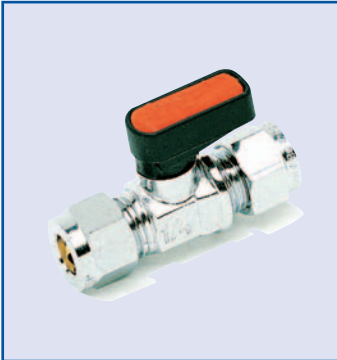

80.6450

ZAWÓR ODCINAJĄCY KULOWY Z PRZYŁĄCZKAMI DO RUREK MIEDZIANYCH
BALL VALVE

D ₁	D	DN	CH	L	A	H	Nr zamówieniowy Code number	
6	-	6	5,5	14-15	46	19	21	80.6450.0606
8	-	8	5,5	14-15	48	19	21	80.6450.0808
10	-	10	8	18-19	51	19	22	80.6450.1010

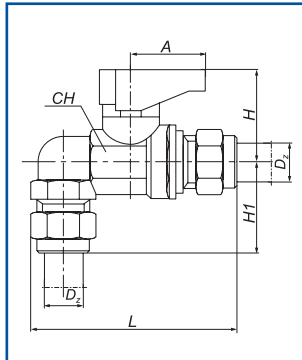

80.6550

ZAWÓR ODCINAJĄCY KULOWY K'TOWY Z PRZYŁĄCZKAMI DO RUREK MIEDZIANYCH, PE, PA
BALL VALVE 90°

D _z	DN	CH	L	H	H ₁	A	Nr zamówieniowy Code number
8	5,5	15	50	21	32	19	80.6550.0808

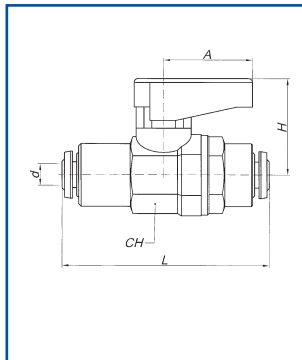

80.6560

ZAWÓR ODCINAJĄCY KULOWY Z PRZYŁĄCZKAMI WTYKOWYMI
BALL VALVE FOR PLASTIC HOSES

PRZEWÓD TUBE d	PRZEWÓD TUBE	CH	L	G	H	Nr zamówieniowy Code number	
4	-	4	14-15	44	19	21	80.6560.0404
6	-	6	14-15	48	19	21	80.6560.0606
8	-	8	14-15	48	19	21	80.6560.0808

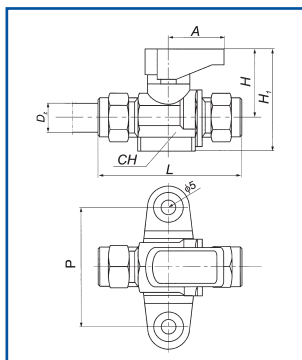

80.6500

ZAWÓR ODCINAJĄCY KULOWY Z PRZYŁĄCZKAMI DO RUREK MIEDZIANYCH Z UCHWYTEM
BALL VALVE FOR Cu, PA TUBES

D _z	DN	CH	L	H	H ₁	P	Nr zamówieniowy Code number
8	5,5	14-15	50	21	32	30	80.6500.0808



SCHEMATY POŁĄCZEŃ

POŁOŻENIE 1

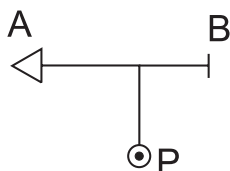

POŁOŻENIE 2

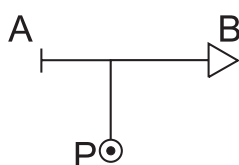

80.1081

ZAWÓR KULOWY 3-DROGOWY TYPU L

3-PORTS BALL VALVE L TYPE

G	Nr zamówieniowy Code number
1/4	80.1081.14L
3/8	80.1081.38L
1/2	80.1081.12L



SCHEMATY POŁĄCZEŃ



POŁOŻENIE 1

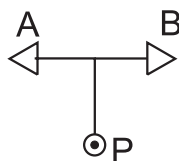

POŁOŻENIE 2

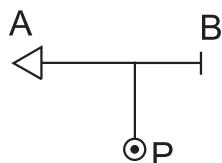

POŁOŻENIE 3

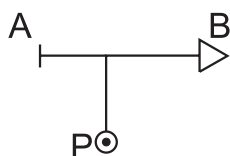

80.1084

ZAWÓR KULOWY 3-DROGOWY TYPU T

3-PORTS BALL VALVE T TYPE

G	Nr zamówieniowy Code number
1/4	80.1084.14T
3/8	80.1084.38T
1/2	80.1084.12T

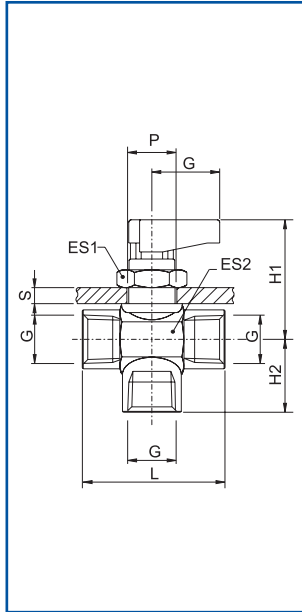

80.6700

ZAWÓR KULOWY TYP L
FEMALE G ISO 228

G	DN	ES1	ES2	L	G	H1	H2	SMax	P	Nr zamówieniowy Code number
1/8-1/8-1/8	5,5	17	17	35	19	33,5	15,5	4,5	14,5	80.6700.181818
1/4-1/4-1/4	5,5	17	17	37	19	33,5	17,5	4,5	14,5	80.6700.141414
3/8-3/8-3/8	7	17	21	42	19	35	19,5	4,5	14,5	80.6700.383838

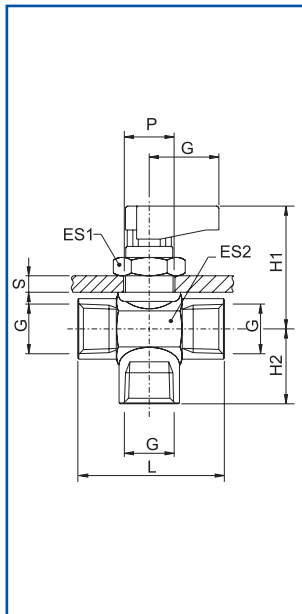
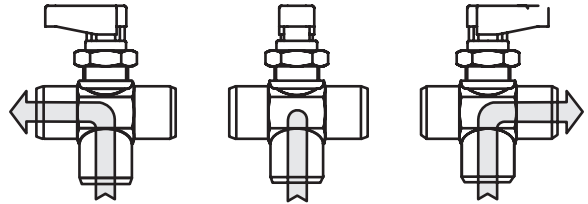

80.6710

ZAWÓR KULOWY TYP T
FEMALE G ISO 228

G	DN	ES1	ES2	L	G	H1	H2	SMax	P	Nr zamówieniowy Code number
1/8-1/8-1/8	5,5	17	17	35	19	33,5	15,5	4,5	14,5	80.6710.181818
1/4-1/4-1/4	5,5	17	17	37	19	33,5	17,5	4,5	14,5	80.6710.141414
3/8-3/8-3/8	7	17	21	42	19	35	19,5	4,5	14,5	80.6710.383838

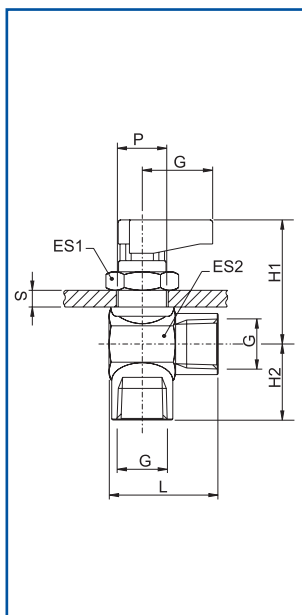
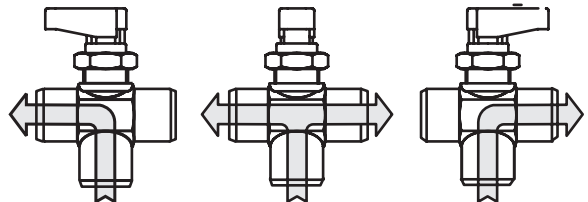

80.6720

ZAWÓR KULOWY TYP L
FEMALE G ISO 228

G	DN	ES1	ES2	L	G	H1	H2	SMax	P	Nr zamówieniowy Code number
1/8-1/8	5,5	17	17	28,5	19	33,5	15,5	4,5	14,5	80.6720.181818
1/4-1/4	5,5	17	17	28,5	19	33,5	17,5	4,5	14,5	80.6720.141414
3/8-3/8	7	17	21	42	19	35	19,5	4,5	14,5	80.6720.383838

