

SZYBKOZŁĄCZKI I KRÓTCE

AUTOMATIC QUICK COUPLINGS



Szybkozłączki i króćce służą do szybkiego łączenia i rozłączania przewodów w instalacjach pneumatycznych. Po rozłączeniu przewodu następuje odcięcie przepływu medium roboczego co nie powoduje strat ciśnienia w układzie.

Szybkozłączki i króćce szczególnie nadają się do podłączania narzędzi pneumatycznych, oraz do stosowania w warsztatach samochodowych.

Automatic quick couplings are used to connecting and disconnecting movable tubes from compressed air systems without stopping the flow upstream, in fact the quick-connect fittings locks the flow in position on disconnecting and allows free flow in position of engagement. They specially match the most pneumatic tools.

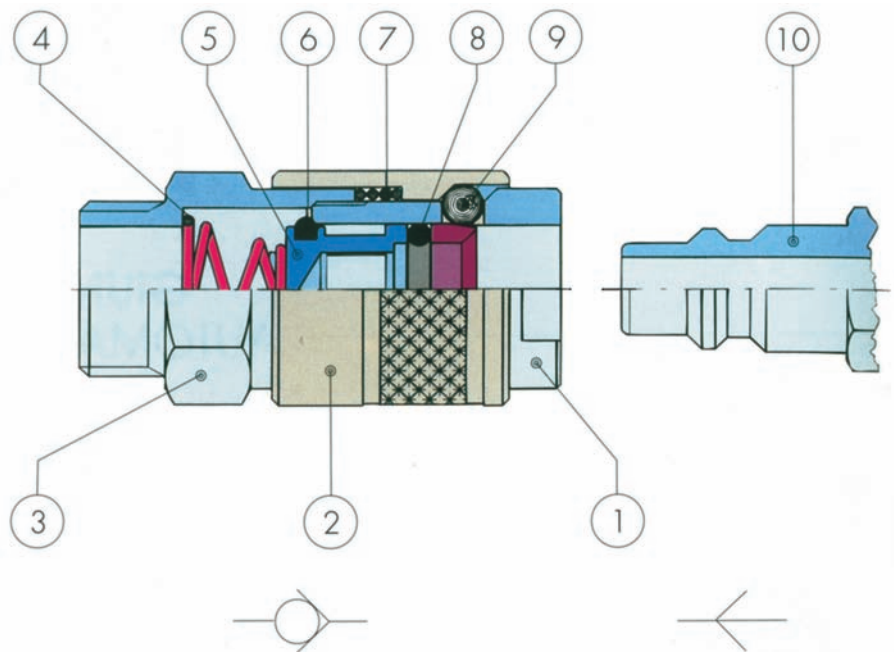

BUDOWA I MATERIAŁY KONSTRUKCYJNE / MATERIALS

- | | |
|--|--------------------------------------|
| 1) Korpus I / Body | - mosiądz / OT 58 UNI 5705 |
| 2) Suwak / Sleeve | - mosiądz / OT 58 UNI 5705 |
| 3) Korpus II / Coupling back part | - mosiądz / OT 58 UNI 5705 |
| 4) Sprężyna / Spring | - stal sprężyn. / Steel AISI 302 |
| 5) Grzybek / Shutter | - mosiądz niklowany / OT 58 UNI 5705 |
| 6) Pierścień uszcz. / O-ring | - NBR 70 |
| 7) Sprężyna / Spring | - stal sprężyn./ Steel AISI 302 |
| 8) Pierścień uszcz. / O-ring | - NBR 70 |
| 9) Kulki / Balls | - stal łożyskowa / Steel AISI 420 |
| 10) Króciec / Plug outline | - mosiądz niklowany / OT 58 UNI 5705 |

DANE TECHNICZNE / TECHNICAL DATA

- **medium robocze:** sprężone powietrze lub inny gaz nieagresywny, ciecze nieagresywne (również podciśnienie)
- *working medium - compressed air or neutral gases, vacu*
- **zakres temperatur pracy:** 0 do +80°C
- *working temperature: 0 +80°C*
- **maksymalne ciśnienie pracy:** 2,0 MPa
- *maximum pressure: 20 bar*

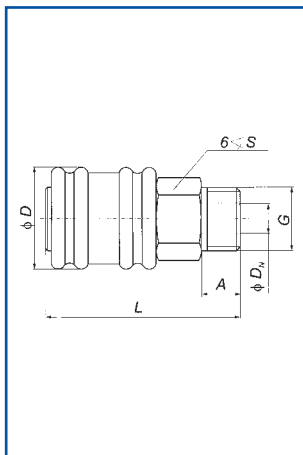

Szybkozłączka DN 7,2

SZYBKOZŁĄCZKA DN 7,2 Z GWIEM ZEWNĘTRZNYM
G1/4 DO G1/2
MALE SOCKET

G	DN	D	L	S	A	Nr zamówieniowy Code number
1/4	7,2	27	43	22	9	80.0243.72.14Z
3/8	7,2	27	43	22	9	80.0243.72.38Z
1/2	7,2	27	46	22	12	80.0243.72.12Z

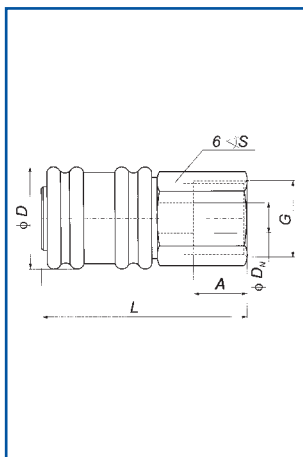

Szybkozłączka DN 7,2

SZYBKOZŁĄCZKA DN 7,2 Z GWIEM WEWNĘTRZNYM
G1/4 DO G1/2
FEMALE SOCKET

G	DN	D	L	S	A	Nr zamówieniowy Code number
1/4	7,2	27	43	22	10	80.0243.72.14W
3/8	7,2	27	43	22	10	80.0243.72.38W
1/2	7,2	27	46	22	10	80.0243.72.12W

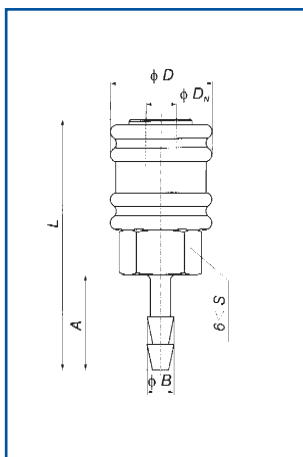

Szybkozłączka DN 7,2

SZYBKOZŁĄCZKA DN 7,2 Z KOŃCÓWKĄ DO WĘŻA
SOCKET WITH REST FOR RUBBER HOSE

B	DN	D	L	S	A	Nr zamówieniowy Code number
6	7,2	27	60	22	30	80.0243.72.06
9	7,2	27	60	22	30	80.0243.72.09
13	7,2	27	60	22	30	80.0243.72.13

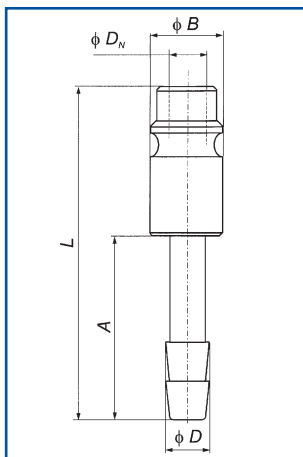
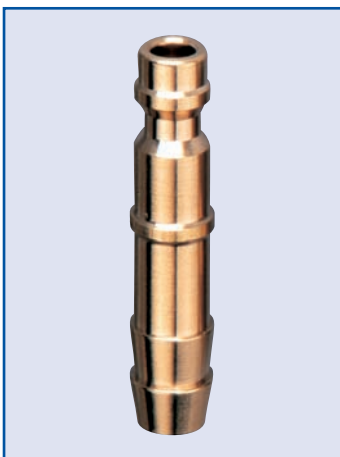

Króciec DN 7,2

KRÓCIEC DN 7,2 Z KOŃCÓWKĄ DO WĘŻA
PLUG WITH REST FOR RUBBER HOSE

D	DN	B	L	A	Nr zamówieniowy Code number
6	7,2	12	53	30	80.0244.72.06
9	7,2	12	53	30	80.0244.72.09
13	7,2	12	53	30	80.0244.72.13

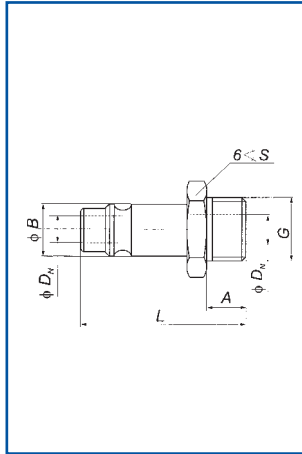
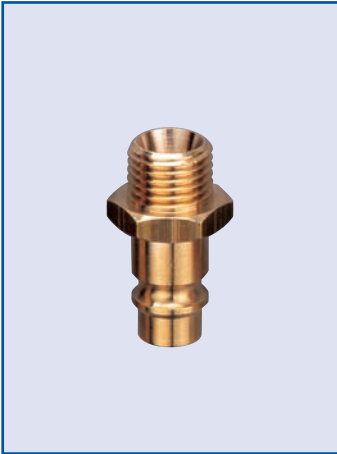

Króciec DN 7,2

KRÓCIEC DN 7,2 Z GWINTEM ZEWNĘTRZNYM G1/8 DO G1/2
MALE PLUG

G	DN	B	L	S	A	Nr zamówieniowy Code number
1/8	7,2	12	32	14	8	80.0244.72.18Z
1/4	7,2	12	32	14	8	80.0244.72.14Z
3/8	7,2	12	32	19	9	80.0244.72.38Z
1/2	7,2	12	32	19	9	80.0244.72.12Z

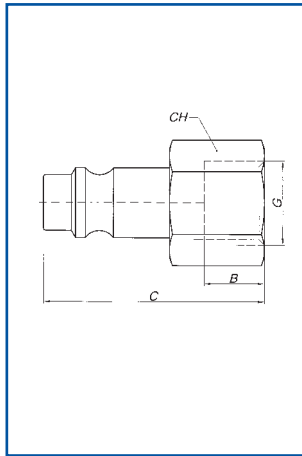

Króciec DN 7,2

KRÓCIEC DN 7,2 Z GWINTEM WEWNĘTRZNYM G1/8 DO G1/2
FEMALE PLUG

G	C	CH	B	Nr zamówieniowy Code number
1/8	32	9	17	80.0244.72.18W
1/4	32	9	17	80.0244.72.14W
3/8	33	10	18	80.0244.72.38W
1/2	33	10	18	80.0244.72.12W

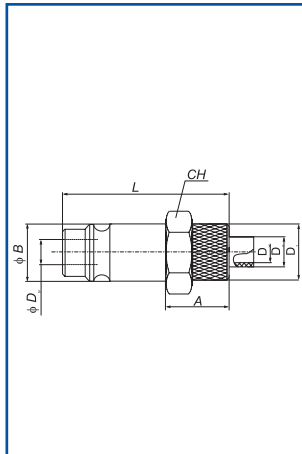
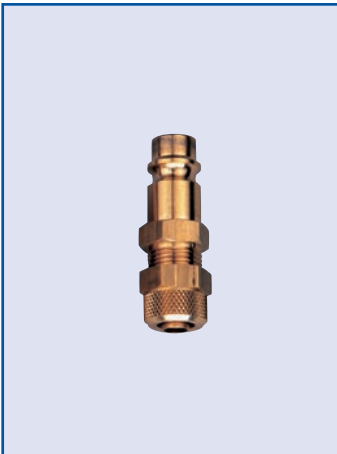

Króciec DN 7,2

KRÓCIEC DN 7,2 Z PRZYŁĄCZKĄ DO WĘŻA Z TWORZYW SZTUCZNYCH
COMPRESSION PLUG

DZ	DW	A	CH	D1	L	Nr zamówieniowy Code number
6	4	10	14	14	41	80.0244.72.0604
8	6	10	15	14	40	80.0244.72.0806
10	8	10	17	14	38	80.0244.72.1008

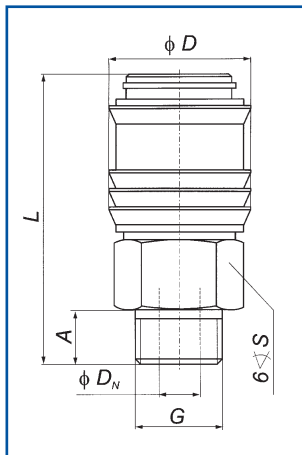

Szybkozłączka DN 5

SZYBKZŁĄCZKA DN 5 Z GWINTEM ZEWNĘTRZNYM G1/8 DO G3/8
MALE SOCKET

G	DN	L	D	S	A	Nr zamówieniowy Code number
1/8	5	36	17	14	7	80.0243.50.18Z
1/4	5	38	17	17	9	80.0243.50.14Z
3/8	5	38	17	19	9	80.0243.50.38Z

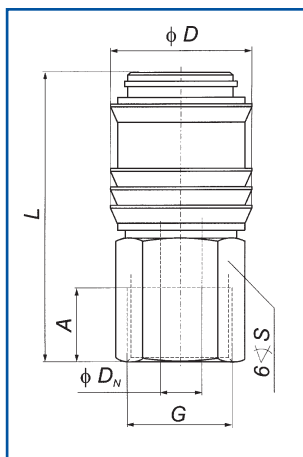

Szybkozłączka DN 5

SZYBKOSZŁĄCZKA DN 5 Z GWINTEM WEWNĘTRZNYM G1/8 DO G3/8

FEMALE SOCKET

G	DN	L	D	S	A	Nr zamówieniowy Code number
1/8	5	36	16	14	8	80.0243.50.18W
1/4	5	38	16	17	8	80.0243.50.14W
3/8	5	39	16	19	8	80.0243.50.38W

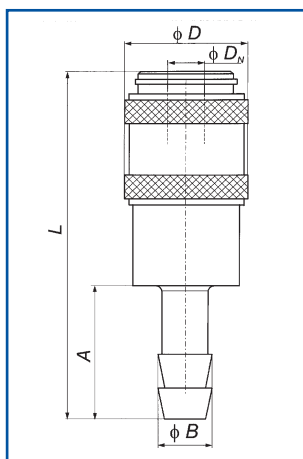

Szybkozłączka DN 5

SZYBKOSZŁĄCZKA DN 5 Z KOŃCÓWKĄ DO WĘŻA

SOCKET WITH REST FOR HOSES

B	DN	D	L	A	Nr zamówieniowy Code number
4	5	16	46	17	80.0243.50.04
5	5	16	46	17	80.0243.50.06
9	5	16	46	17	80.0243.50.09

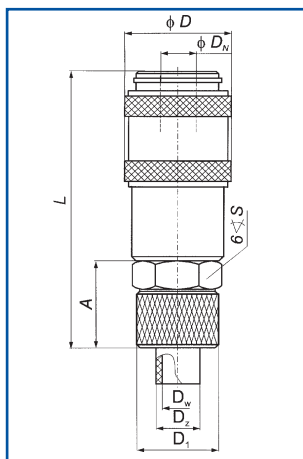

Szybkozłączka DN 5

SZYBKOSZŁĄCZKA DN 5 Z PRZYŁĄCZKĄ DO WĘŻY Z TWORZYW SZTUCZNYCH

SOCKET WITH HOSES ADAPTOR

DZ	DW	D _N	L	D	A	D ₁	S	Nr zamówieniowy Code number
6	4	5	40	16	11	14	14	80.0243.50.0604
8	6	5	40	16	11	14	14	80.0243.50.0806

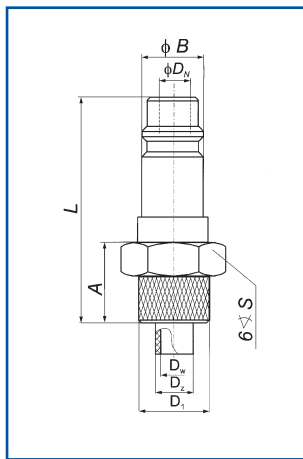

Króciec DN 5

KRÓCIEC DN 5 Z PRZYŁĄCZKĄ DO WĘŻY Z TWORZYW SZTUCZNYCH

COMPRESSION PLUG

DZ	DW	D _N	L	B	A	D ₁	S	Nr zamówieniowy Code number
6	4	5	30	9	11	12	12	80.0244.50.0604
8	6	5	30	9	11	14	14	80.0244.50.0806

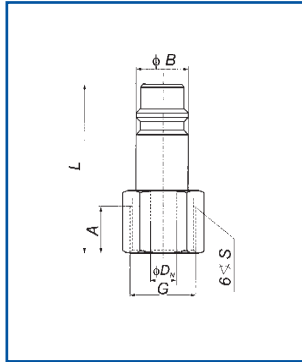

Króciec DN 5

KRÓCIEC DN 5 Z GWINTEM WEWNĘTRZNYM G1/8 DO G3/8
FEMALE PLUG

G	DN	L	B	S	A	Nr zamówieniowy Code number
1/8	5	25	9	14	7	80.0244.50.18W
1/4	5	25	9	16	8	80.0244.50.14W
3/8	5	25	9	19	9	80.0244.50.38W

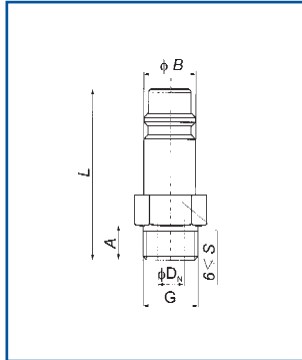
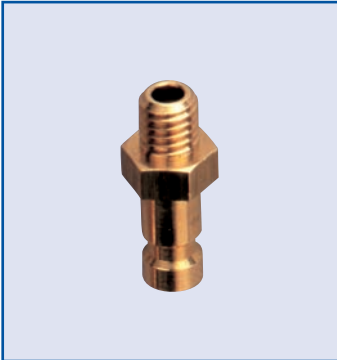

Króciec DN 5

KRÓCIEC DN 5 Z GWINTEM ZEWNĘTRZNYM G1/8 DO G3/8
MALE PLUG

G	DN	L	B	S	A	Nr zamówieniowy Code number
1/8	5	24	9	14	9	80.0244.50.18Z
1/4	5	26	9	16	9	80.0244.50.14Z
3/8	5	28	9	19	9	80.0244.50.38Z

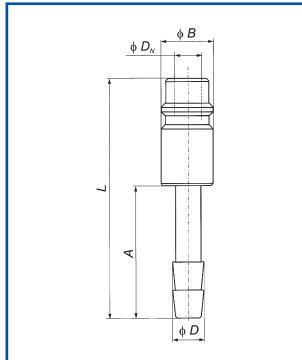

Króciec DN 5

KRÓCIEC DN 5 DO WĘŻA
ELBOW COMPRESSION PLUG

DW	DN	A	L	Nr zamówieniowy Code number
4	5	31	18	80.0244.50.04
6	5	31	18	80.0244.50.06
9	5	31	18	80.0244.50.09

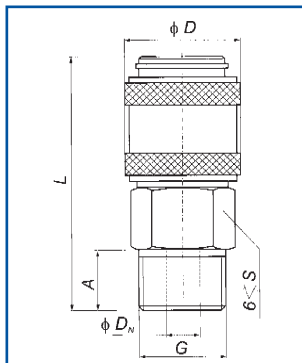

Szybkozłączka DN 2,7

SZYBKZŁĄCZKA DN 2,7 Z GWINTEM ZEWNĘTRZNYM M5 I G1/8
MALE SOCKET

G	DN	D	L	S	A	Nr zamówieniowy Code number
M5	2,7	10	26	9	7	80.0243.27.05Z
1/8	2,7	10	28	11	7	80.0243.27.18Z

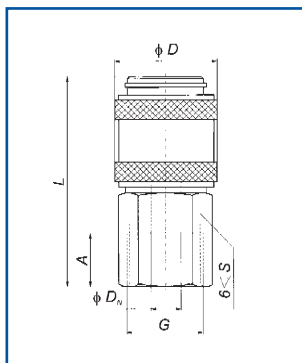

Szybkozłączka DN 2,7

SZYBKZŁĄCZKA DN 2,7 Z GWINTEM WEWNĘTRZNYM M5 I
G1/8
FEMALE SOCKET

G	DN	D	L	S	A	Nr zamówieniowy Code number
M5	2,7	10	26	9	7	80.0243.27.05W
1/8	2,7	10	28	11	7	80.0243.27.18W

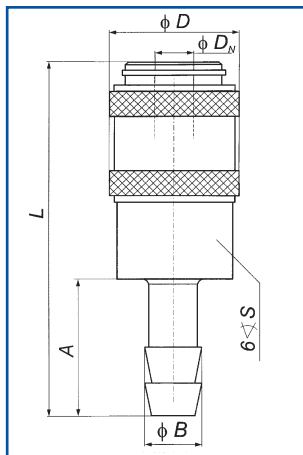

Szybkozłączka DN 2,7

SZYBKZŁĄCZKA DN 2,7 Z KOŃCÓWKĄ DO WĘŻA
SOCKET WITH REST FOR HOSE

B	DN	D	L	A	Nr zamówieniowy Code number
3	2,7	10	35	8	80.0243.27.03
4	2,7	10	35	8	80.0243.27.04

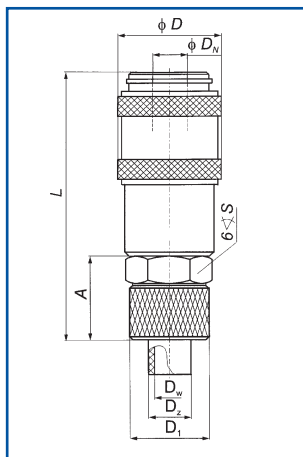

Szybkozłączka DN 2,7

SZYBKZŁĄCZKA DN 2,7 Z PRZYŁĄCZKĄ DO WĘŻY Z TWO-
RZYW SZTUCZNYCH

SOCKET WITH REST FOR HOSE

DW	DZ	DN	L	D	A	D ₁	S	Nr zamówieniowy Code number
4	6	2,7	34	10	14	9	9	80.0243.27.0604

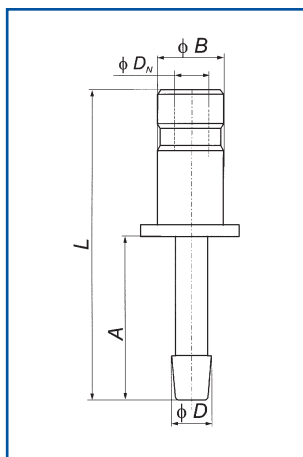

Króciec DN 2,7

KRÓCIEC DN 2,7 Z KOŃCÓWKĄ DO WĘŻA

PLUG WITH REST FOR HOSES

D	DN	L	A	B	Nr zamówieniowy Code number
4	2,7	24	13	5	80.0244.27.04

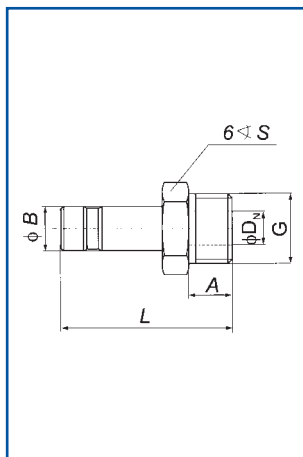

Króciec DN 2,7

KRÓCIEC DN 2,7 Z GWINTEM ZEWNĘTRZNYM M5 I G1/8

MALE PLUG

G	DN	L	B	A	S	Nr zamówieniowy Code number
M5	2,7	17	5	5	7	80.0244.27.05Z
1/8	2,7	20	5	7	11	80.0244.27.18Z

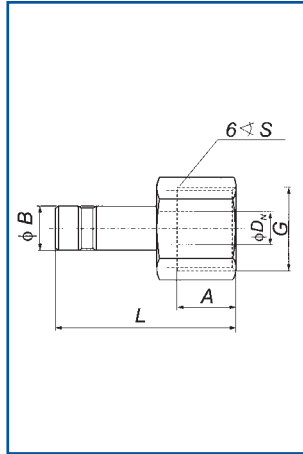

Króciec DN 2,7

KRÓCIEC DN 2,7 Z GWINTEM WEWNĘTRZNYM M5 I G1/8

G	DN	L	B	A	S	Nr zamówieniowy Code number
M5	2,7	17	5	5	8	80.0244.27.05W
1/8	2,7	19	5	7	12	80.0244.27.18W

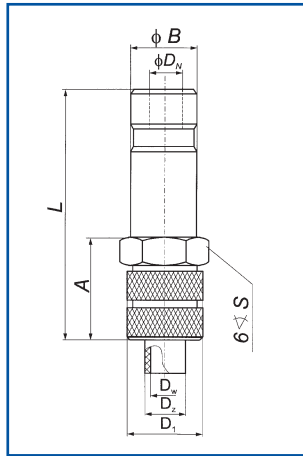

Króciec DN 2,7

KRÓCIEC DN 2,7 Z PRZYŁĄCZKĄ DO WĘŻY Z TWORZYW SZTUCZNYCH

COMPRESSION PLUG

DW	DZ	DN	L	A	D ₁	B	S	Nr zamówieniowy Code number
4	6	2,7	25	11	9	5	8	80.0244.0604